

BACK



LUBRICATING EQUIPMENT



LARGE VEHICLE LUBRICATING SYSTEM

This is an example of layout for centralized lubricating systems for large-sized motor vehicles. Various reels for supplying grease, oils and compressed air are provided at the ceiling, with a power twin ace lift as the center unit. Furthermore, labor-saving equipment is employed at each

operation for waste oil disposal, washing parts, underbody washing and application of bearing grease. This is a system which realizes the modernization and rationalization for service shops for large-sized motor vehicles.

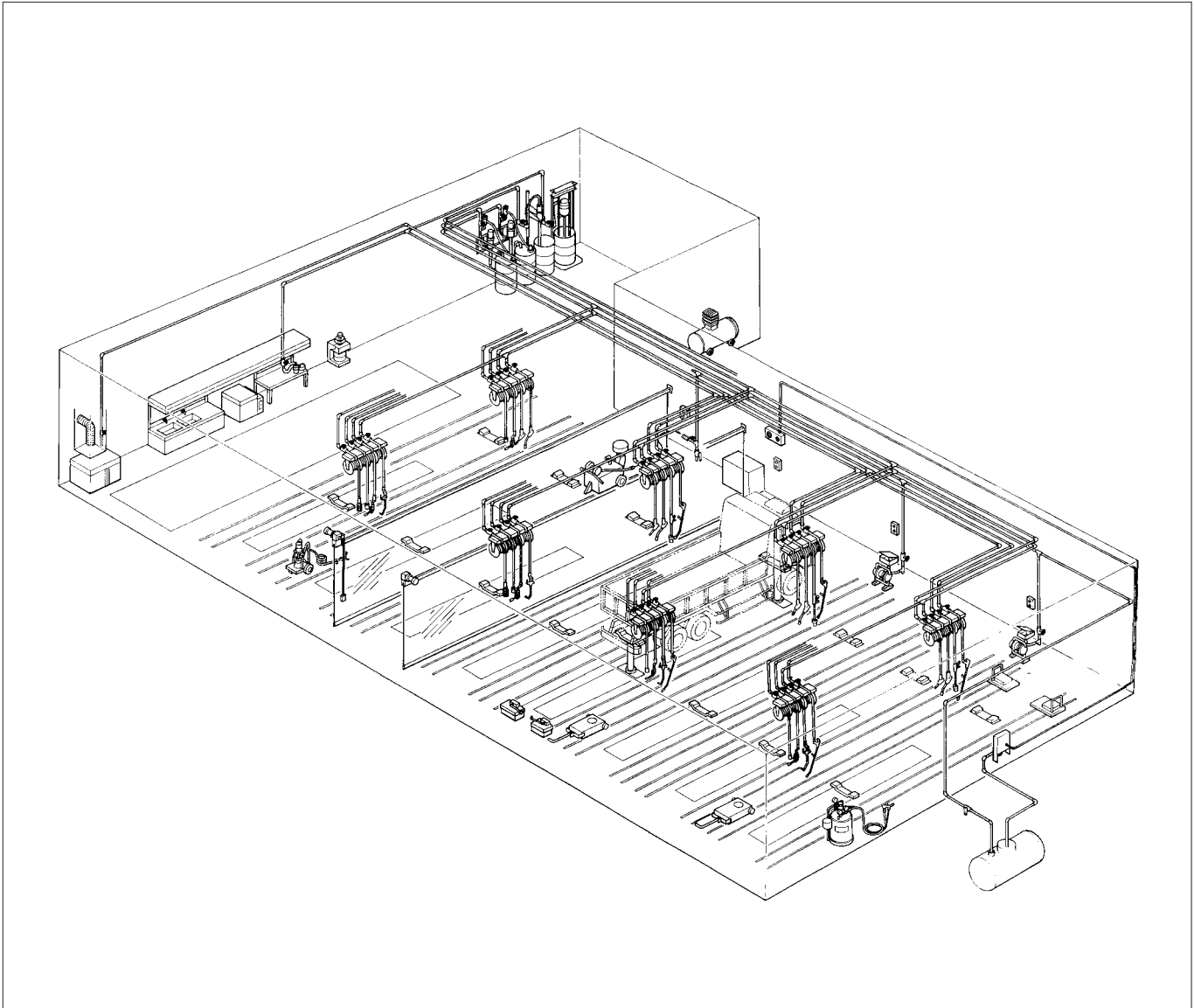

• Main Equipment

- Type 230 Drum Pump Unit (60:1)
- Type 110 Drum Pump Unit (50:1)
- Type 110 Pump Unit (Wall mounted type)
- LO Level alarm
- R-4 Rail for mounting
- SR-4G15 Reel for Oil $\frac{1}{2} \times 15M$
- Preset Type Gun W/Flow Meter
- Hose W/Non-Drip Nozzle
- Pipe W/Non-Drip Nozzle
- SR-3C15 Reel for Grease $\frac{3}{8} \times 45M$
- Grease Gun
- SR-3A15 Reel for Air $\frac{3}{8} \times 45M$
- RK-S Bracket for SR Mounting
- SR-3WH15 Reel for Hot Water $\frac{3}{8} \times 15M$
- Stp Gun for Car Washer
- SR-4W15 Water Reel $\frac{1}{2} \times 10M$
- Special Reel for Bearing Grease
- Gun for Bearing Grease
- L Type Non-Drip Nozzle
- DC-100N Drain Cart
- DB-01A Drain Box
- Diaphragm Pump
- UNC-50 Uni-Coater
- Oil-Gun for Motor Oil
- DC-77P Drain Cart
- Clean Master
- Twin Post Lift
- Hot Water Washer
- Auto Parts Washer
- BGP-100N Bearing Grease Lubricator
- Wheel Dolly
- Waste Oil Tank, High-Low Level Control

OVERHEAD HOSEREEL SET

The SR type hose reel is installed at the ceiling or wall surface of working places of service shops, gas stations or various production factories, thus greatly contributing to labor-saving in supplying oils and grease.

The built-in stopper locks the reel hose at your desired length.

After completion of the operation, the spring allows the hose to retract automatically. Grease is sucked from an air powered pump which is provided at an oil storage inside the service shop. Since the grease is supplied under pressure to the hose reel, it is unnecessary for the operator to leave his place to get the grease.

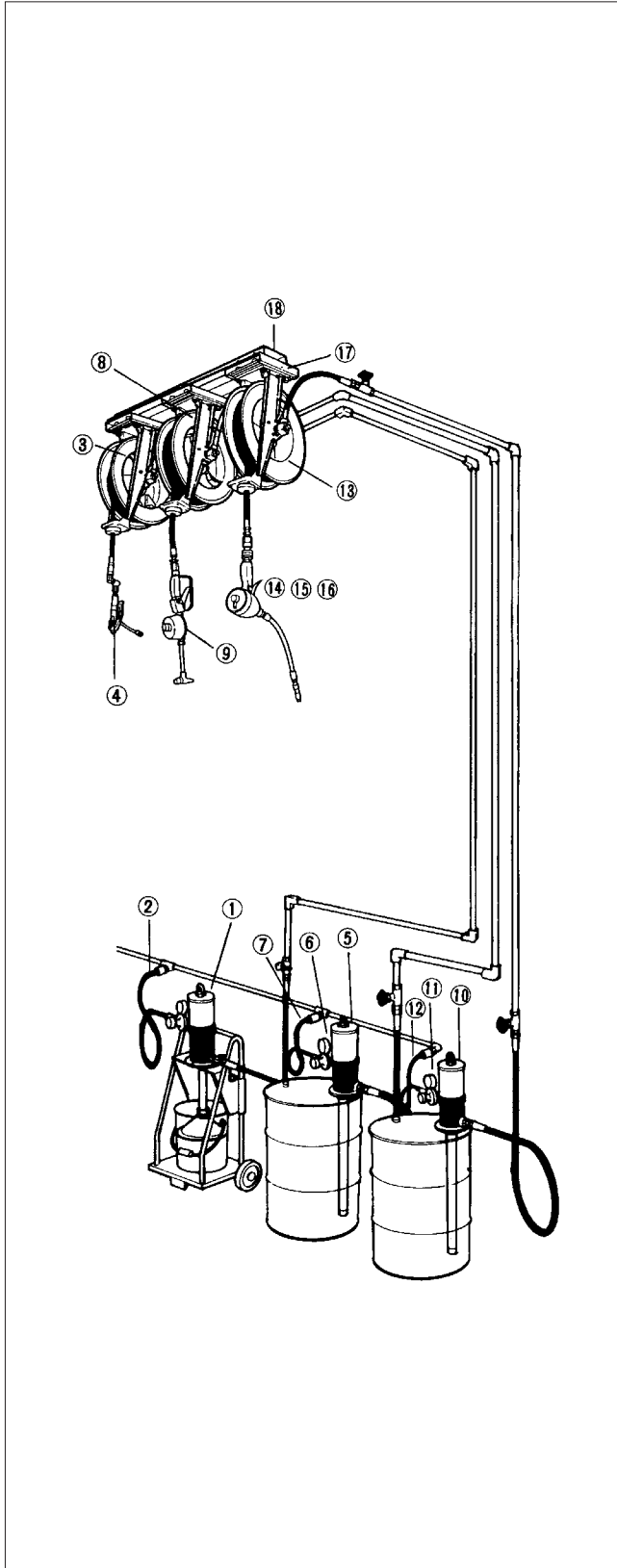

• Composition

Chassis

- ① 880068 SKR-110T45 110 Type 45:1 Grease Pump Unit for Pail can
- ② 695034 Hose for oil $\frac{1}{4} \times 2.5M$
- ③ 851242 SR-2C10 Hose Reel for grease ($\frac{1}{4} \times 10M$)
- ④ 850204 Grease Gun W/nozzle, swivel joint

Gear Oil (or Motor Oil)

- ⑤ 850151 DR-110A5 110 Type 5:1 Oil Supply Pump for drum can
- ⑥ 800434 Air Regulator
- ⑦ 800938 Hose for oil $\frac{1}{2} \times 2M$
- ⑧ 851250 SR-3G10 Hose Reel for oil
- ⑨ 851138 Oil Gun W/Flow Meter

Gear Oil or Motor Oil

- ⑩ 850151 DR-110A5 110 Type 5:1 Oil Supply Pump for drumcan
- ⑪ 800434 Air Regulator
- ⑫ 800938 Hose for oil $\frac{1}{2} \times 2M$
- ⑬ 851251 Hose Reel for oil ($\frac{1}{2} \times 10M$)
- ⑭ 801151 Swivel Joint ($\frac{1}{2} \times \frac{1}{2}$)
- ⑮ 801429 Batch Meter
- ⑯ 801195 Non-Drip Nozzle H
- ⑰ 801951 Mounting Bracket
- ⑱ 704441 R-3 Mounting Rail for 3sets

HOSEREEL SERIES

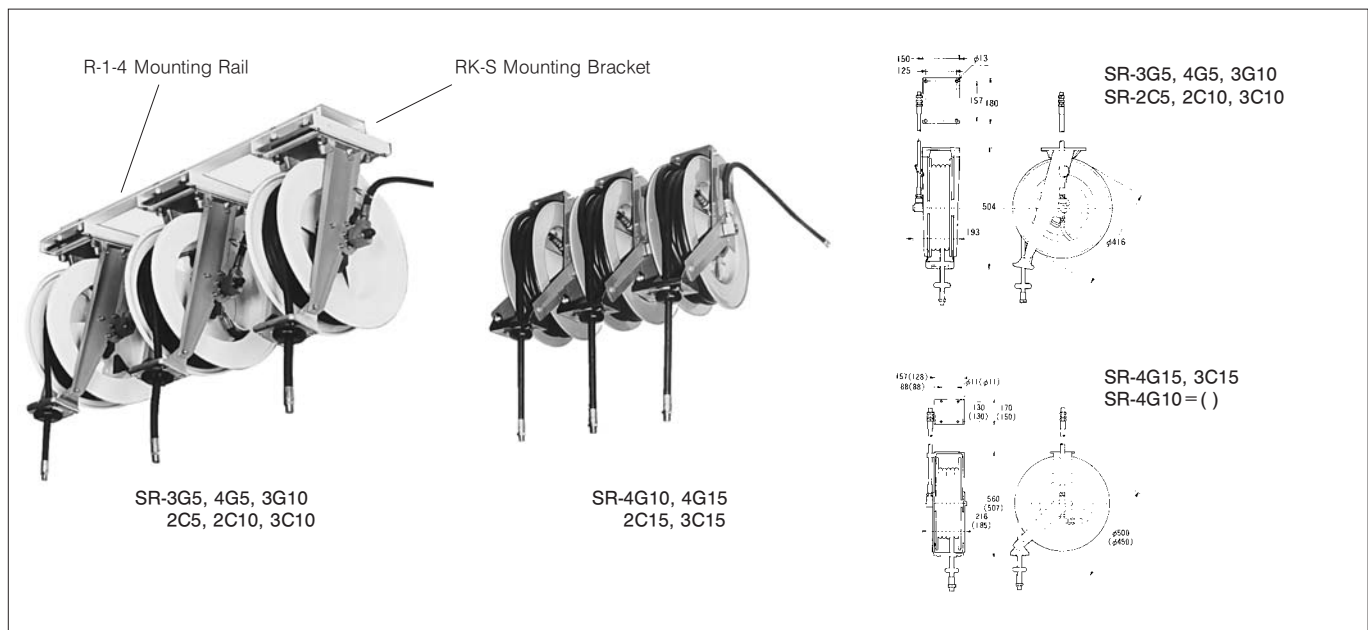

Model	Used for	Pressure kgf/cm ²	Outlet Hose		Inlet Hose			Weight kg
			φ" × L	Coupler	φ" × L	Coupler	Remarks	
SR-2C5	Chassis	350	1/4 × 5m	PF1/4(M)	1/4 × 1m	PT1/4(M)	W/Hose Union	12.9
SR-2C10	Chassis	350	1/4 × 10m	PF1/4(M)	3/8 × 1m	PT1/4(M)	W/Hose Union	14.6
SR-3C10	Chassis	350	3/8 × 10m	PF3/8(M)	3/8 × 1m	PT3/8(M)	W/Hose Union	16.7
SR-3C15	Chassis	350	3/8 × 15m	PF3/8(M)	3/8 × 1m	PT3/8(M)	W/Hose Union	39.2
SR-3G5	Oil	70	3/8 × 5m	PT3/8(M)	3/8 × 1m	PT3/8(M)	W/Hose Union	12.7
SR-3G10	Oil	70	3/8 × 10m	PT3/8(M)	3/8 × 1m	PT3/8(M)	W/Hose Union	14.2
SR-4G5	Oil	70	1/2 × 5m	PT1/2(M)	1/2 × 1m	PT1/2(M)	W/Hose Union	13.3
SR-4G10	Oil	70	1/2 × 10m	PT1/2(M)	1/2 × 1m	PT1/2(M)	W/Hose Union	24
SR-4G15	Oil	70	1/2 × 15m	PT1/2(M)	1/2 × 1m	PT1/2(M)	W/Hose Union	35.5

Mounting of Hose Reel



• Mounting Bracket

Model	Dimensions (W × D × H) mm	Weight kg
RK-S	250 × 149 × 35	4

• Mounting Rail

Model	Reel Mounting Q'ty	Length mm	Weight kg
R-1	1	140	1.5
R-2	2	520	5.3
R-3	3	900	9.2
R-4	4	1,280	13

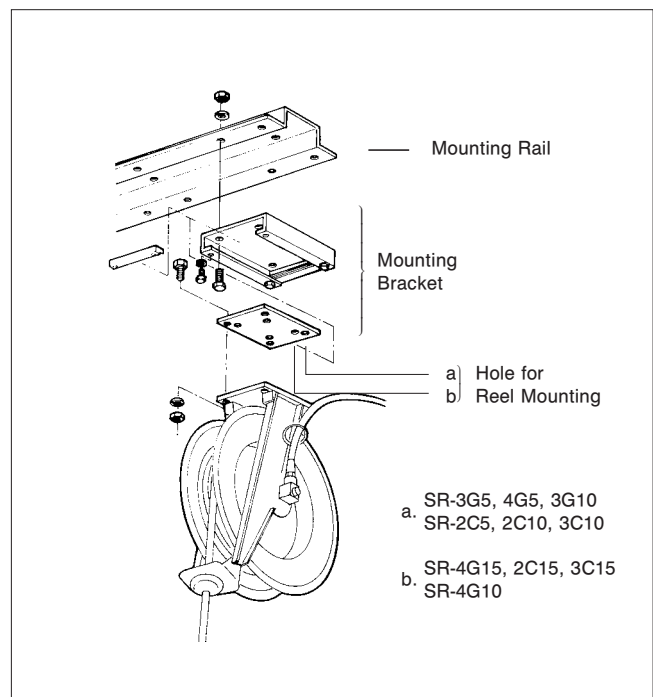

ACCESSORY FOR HOSEREEL

You can select accessories best suited for your rationalization of lubrication works and lubricating oil piping and the layout that has been arranged in accordance with kinds of lubrication oils and working places.

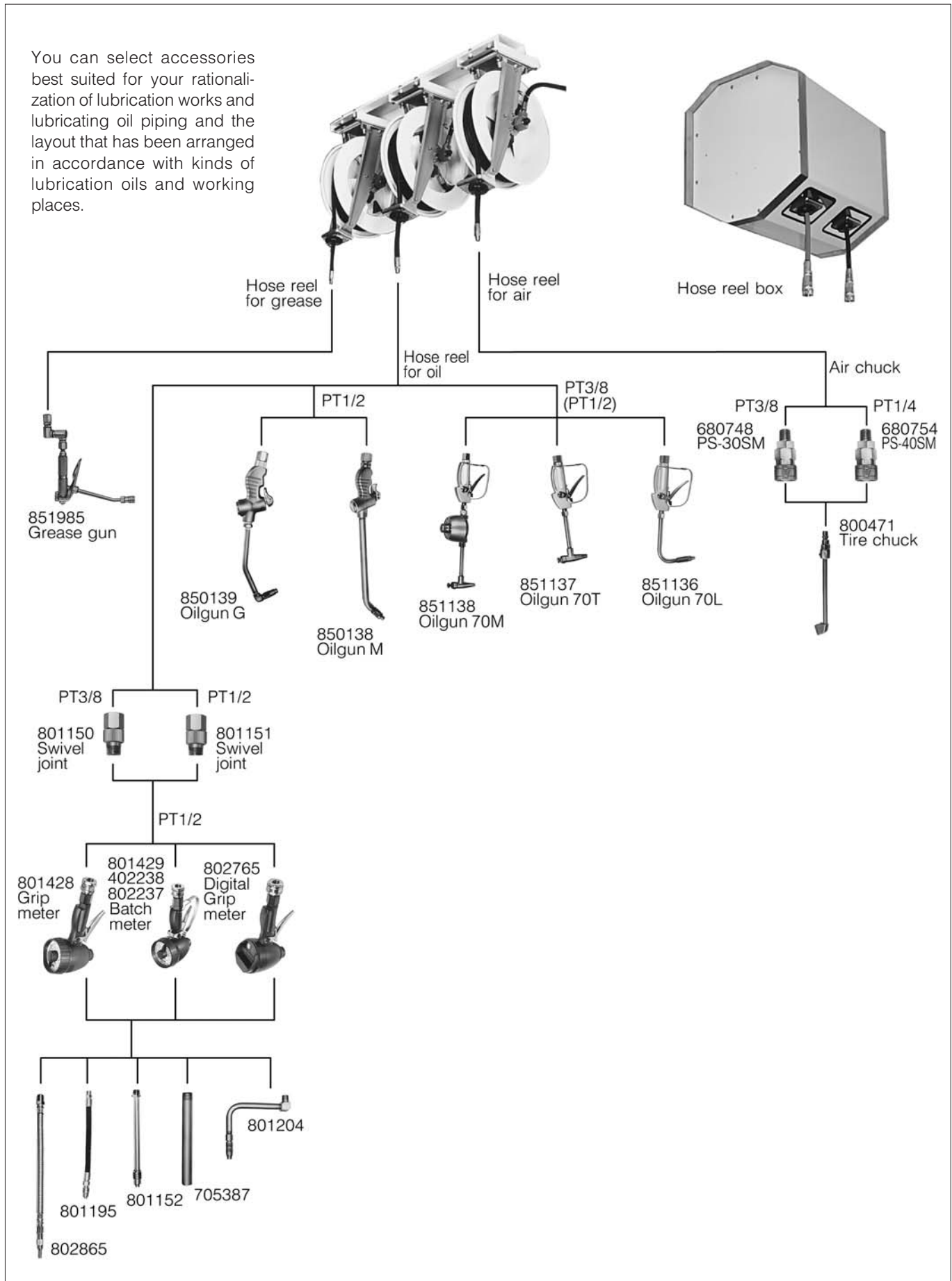

ACCESSORIES FOR LUBRICATOR

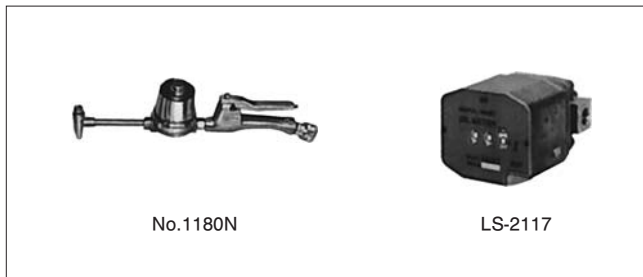

Model	Description
851942	Flow Meter W/Filter (for STB)
800-807	Oil Meter (for SGR)
No.1180N	Oil Gun W/Flow Meter
LS-2117	Flow Meter (Digital Indication)

HOSEREEL HR SERIES



Model	Use	Dimensions (L×W×D) mm	Weight kg	Accessories		
				Oil Feeding Hose	Connecting Hose	Gun
HR-C	for Grease	570×190×490	37	High Pressure Oil Proof 1/4×7m	High Pressure Oil Proof 1/4×0.7m	850204 High Pressure Grease Gun
HR-G	for Oil	570×190×490	38	Oil Proof 3/8×7m	Oil Proof 3/8×0.7m	851138 Oil Gun 70M (with Flow Meter)
HR-A	for Air	570×190×490	35	Oil Proof 3/8×7m	Oil Proof 3/8×0.7m	AC-67 Main Body, AC-65 Button Head Adaptor

OIL PUMP

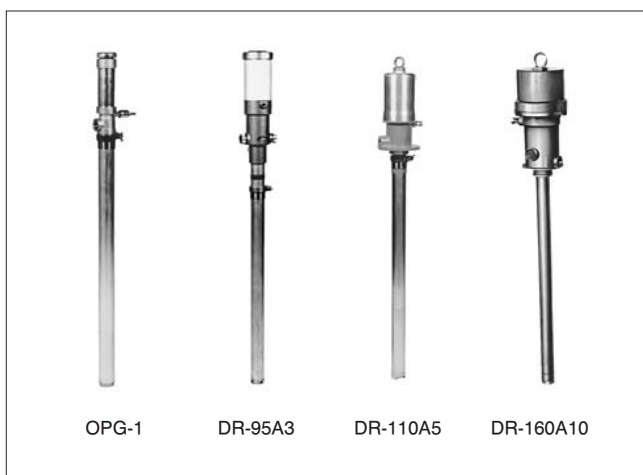

Model	OPG-1	DR-95A3	DR-110A5	DR-160A10
Pump Ratio	1×1	3×1	5×1	10×1
Output Volume Max. ℓ /min.	22	22	12.5	12
Height mm	1,317	1,337	1,362	1,362
Weight kg	5	7.7	11.7	17

OIL PUMP (PANEL MOUNTING TYPE)



KP-110
(KP-160)

This is a unit in which the pump is built into the panel of a wall mounting type. The replacement of a drum can be performed simply by changing the suction pipe.

Model	KP-110	KP-160
Pump Capacity	Same as SH-110A5	Same as SH-160A10
Contents	Panel Unit Suction Hose Air Regulator	Panel Unit Suction Hose Air Regulator

This is the set of an oil pump and a hose reel.

This set is a best suited especially for those operations which require great flow rates, e.g. lubrication for large-sized motor vehicles or construction machinery.

• Example for Set W/Lubrication Reel

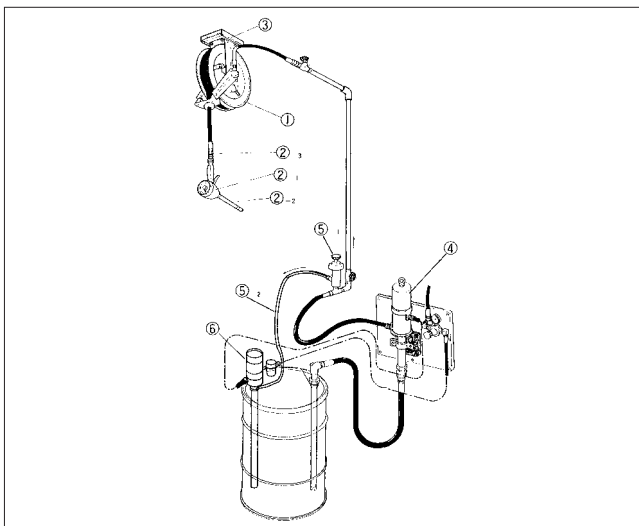

No.	Description	Q'ty	Remarks
①	SR-4G10 Hose Reel	1	1/2 × 10m
②-1	Grip meter	1	W/Flow Meter
②-2	Non-drip Nozzle P	1	
②-3	Swivel joint	1	
③	RK-S Mounting Bracket	1	
④	DR-110A5 Pump	1	Pump Ratio 5 × 1
⑤-1	Relief Valve	1	
⑤-2	Return Hose	1	
⑥	LO Level Alarm	1	

GREASE PUMP UNIT



This is a pump unit capable of sucking grease from a pail or a drum in an effective way. The pump unit can be used up to grease equivalent to NLGI No. 2.

Model	SKR-110M50SAL	DR-110A50AL
Application	16kg Pail can	200kg Drum can
Pump	PD110A50	DR110A50
Height mm	1,073	1,615
Lift Up Overall Length mm	1,301	2,565
Weight kg	38	113

LUBRICATING EQUIPMENT

LUBRICATOR



Model	SKR-57	SKR-66	SGR-57
Pump Ratio	Grease Lubricator, 40 × 1	Grease Lubricator, 40 × 1	Oil Lubricator, 1.8 × 1
Output Pressure MPa(kgf/cm ²)	22.5 (230)	22.5 (230)	22.5 (230)
Output Volume	350g/min.	350g/min.	7 ℓ /min.
Air Pressure Required MPa(kgf/cm ²)	0.69 (7)	0.69 (7)	0.69 (7)
Capacity	Pail can, Sq. can contained	Pail can, Sq. can contained	20 ℓ
Height, Weight	784mm, 15.3kg	866mm, 19.4kg	784mm, 18.2kg

LUBRICATOR (POWERED PUMP TYPE)

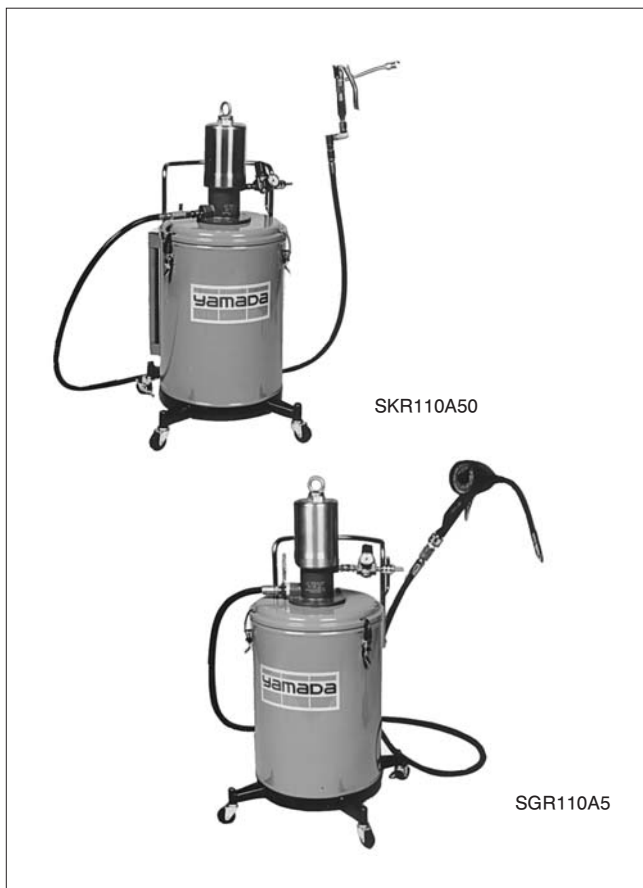

Model	SKR110A50	SGR110A5
Pump Ratio	Grease, 50 × 1	Oil, 5 × 1
Output Pressure MPa(kgf/cm ²)	Max. 24.5 (250)	Max. 1.47 (15)
Output Volume g/min.	Max. 1,200	Max. 10
Air Pressure Required MPa(kgf/cm ²)	0.2 – 0.69 (2 – 7)	0.2 – 0.69 (2 – 7)
Capacity	Pail can, Sq. can contained (16 – 18kg)	50 ℓ
Weight kg	39	27.5
Standard Accessories	High Pressure Hose, Grease Gun, Follow Plate, Air Regulator	Grip Meter, Hose, Non-Drip Nozzle, Swivel Joint, Air Regulator

ACCESSORIES FOR LUBRICATOR



Model	Description
851942 850206 LS-2111	Flow Meter, with Filter (for STB) Low-Pressure Oil Gun Flow Meter, with Reckoning Meter
851985	High-Pressure Grease Gun with CNP-1 Nozzle, 802910 Swivel Joint

OIL DRAIN



Model	OD-57	OD-70	OD-70APN	OD-70PG
Operation	—	—	Drain (Air)	Drain (Manual)
Output Volume	—	—	48 ℓ /min.	10 ℓ /40rev.
Oil Pan Height	mm	802 – 1,615	1,060 – 1,634	1,060 – 1,634
Reservoir Capacity	%	20	55	55
Weight	kg	12.6 (Water Oil Can Included)	13.0	21
Standard Accessories	Water Oil Can, Over Flow Gauge	with Drain Coupler	Air Pump Drain Hose (2m)	Rotary Pump Drain Hose (2m)

DRAIN CART



Model		DC-77P	DC-100N
Reservoir Capacity	ℓ	77	100
Oil Pan Height	mm	190	800 – 1,590
Pump		Plunger	Suction
Output Volume	ℓ /min.	12	15
Weight	kg	43.3	89.3

BEARING GREASE PACKER



This grease packer is capable of grease filling for wheel bearings of small-sized vehicles to large-sized vehicles without loss within a short length of time.

Moreover, it is possible to use grease containers in commercial use as they are without a need for refilling.

Model		BGP-100N
Output Pressure	MPa(kgf/cm ²)	22.5 (230)
Output Volume	g/min.	350
Air Consumption	ℓ /min.	130N
Grease		NLGI No.0-3 (16kg Pail can)
Dimensions (W × D × H)	mm	450 × 600 × 1,040
Weight	kg	33.7

• Attachment Kit

Model	Contents
851661	Gun (BGP-100-14), H.P. Hose (BGP-100-15) Nozzle (BGP-100-11, BGP-100-12, BGP-100-13)

HIGH PRESSURE GREASE PUMP

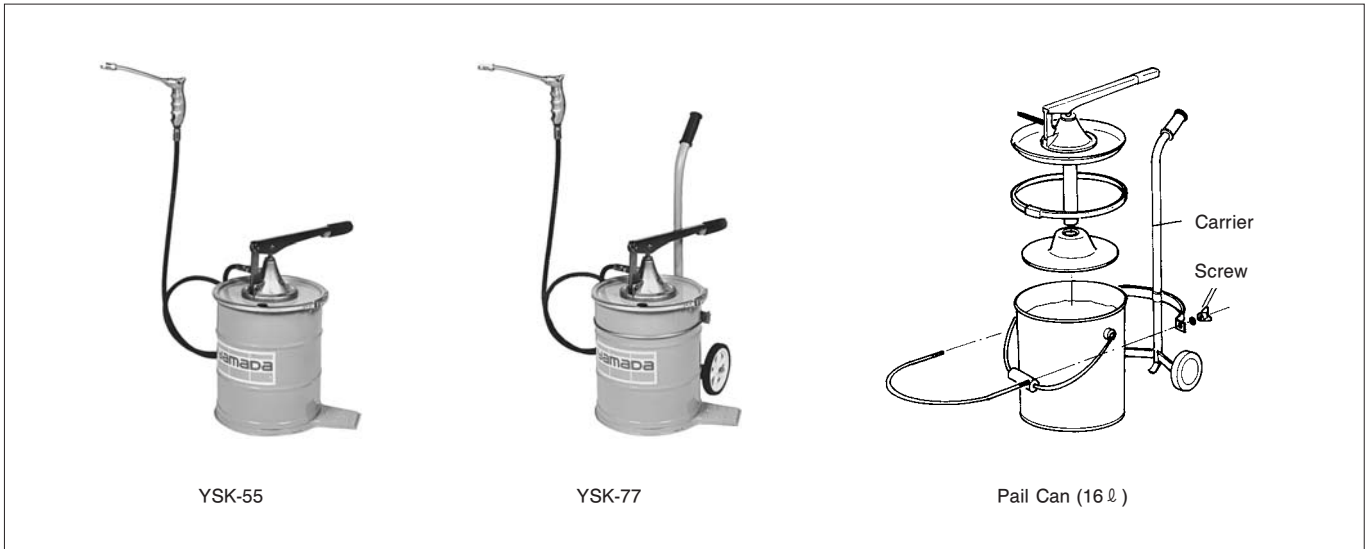

Model	YSK-55	YSK-77
Output Pressure, Output Volume Pump Stroke, Container Capacity Overall Height, Weight	Max. 2.45MPa, 3.2g/stroke 38 – 43mm, 16 ℓ 495mm, 8.7kg	Max. 24.5MPa, 3.2g/stroke 38 – 43mm, 16 ℓ 800mm, 11.3kg
Standard Accessories	Grease Gun, H.P. Hose 2m Follower Plate	Grease Gun, H.P. Hose 2m Follower Plate, Carrier

Long type hose (3m, 5m, 7m) is available as optional parts.

OIL BUCKET PUMP



Model		STB-57	STB-67	STB-77
Output Volume	cc/stroke	40	40	40
Pump Stroke	mm	50	50	50
Container Capacity	ℓ	20	20	20
Overall Height	mm	539	795	795
Weight	kg	7.4	11.3	9.9
Standard Accessories		H.P. Hose 2m	H.P. Hose 2m Carrier Flow Meter	H.P. Hose 2m Carrier

LUBRICATING EQUIPMENT

GREASE OIL PUMP



Model		VO-8	VO-50
Output Pressure	MPa(kgf/cm ²)	2.0 (20)	4.9 (50)
Output Volume	cc/stroke	20	24
Oil Tank Capacity	ℓ	8	15
Overall Height	mm	423	520
Weight	kg	5.4	9.6

Standard Accessories: Button Head Adaptor, High Pressure Hose

HIGH PRESSURE GREASE PUMP

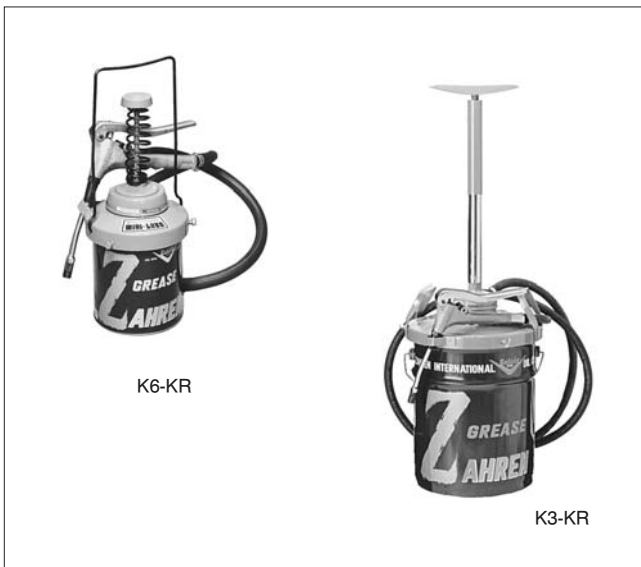

Featuring a high delivery pressure, this grease pump can perform lubrication readily for even restricted grease fittings.

Model		K6-KR	K3-KR
Description		MINI-LUB	SUPER-LUB
Output Pressure	MPa(kgf/cm ²)	68.6 (700)	68.6 (700)
Output Volume	cc/stroke	Max. 3	Max. 3
Filling Volume	cc	Approx. 50	Approx. 130
Pressure Proof Hose		φ 25 × 1.5m	φ 25 × 3m
Remarks		Grease can (2.5kg) or mini-tank	Grease Pail can (16 – 18kg)

GREASE GUN



Model	Capacity cc	Weight kg	Length mm (without Nozzle)	Max. Output Pressure MPa(kgf/cm ²)	Application	
					Pack	Cartridge
KH-120	140	0.55	252	19.6 (200)	Can	Can
KH-35	400	1.23	320	24.5 (250)	Can	Can
KH-1100	1,000	3.50	432	24.5 (250)	Can	Can't
KH-350	500	2.07	422	49.0 (500)	Can	Can't
KH-32	200	1.45	405	24.5 (250)	Can	Can't
KH-250	300	1.67	406	24.5 (250)	Can	Can't

GREASE GUN (CARTRIDGE)

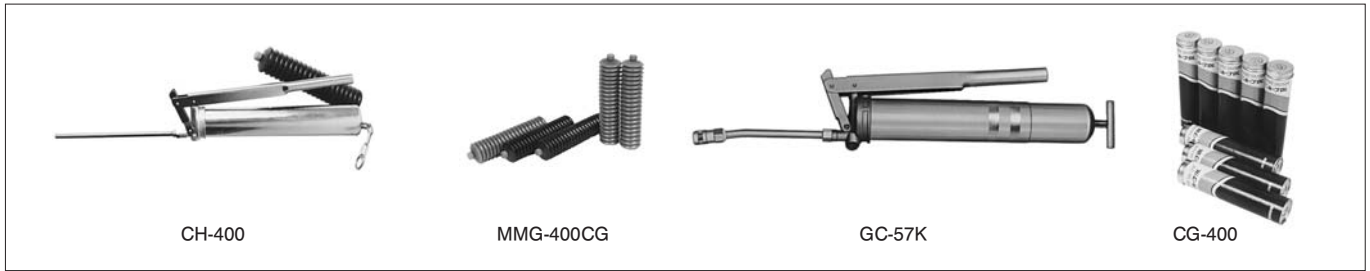

• Grease Gun

Model	Capacity g	Max. Pressure MPa(kg/cm ²)	Length mm (without Nozzle)	Weight kg
CH-400	400	49.0 (500)	400	1.7
GC-57K	500	24.5 (250)	421	1.7

• Grease for GC-57K

Model	Name of Grease	Remarks
CG-400	Uni Lub DL	400g 30pcs.

• Grease for CH-400

Model	Name of Grease	Remarks
MMG-400-CG	Chassis grease	NLGI No.1 20pcs.
MMG-400-MP	Lithium grease	NLGI No.2 20pcs.
MMG-400-MO	Molybdenum grease	NLGI No.2 20pcs.

NOZZLE & MICRO-HOSE

You can select your suitable nozzles or micro-hoses in cases where the lubrication nozzle of a lever type grease gun or the SK type hand bucket pump does not match with the shape of grease fittings or the grease fittings are located at points hard to be lubricated.

These nozzles can be attached after the original standard

nozzles have been removed.

However, the SPK-1, 2, 3 micro-hoses can not be used for the SKR type chassis lubricator. In this case, use the SPK-5 type micro-hose which can be operated by attaching it to the tip-end of the nozzle.

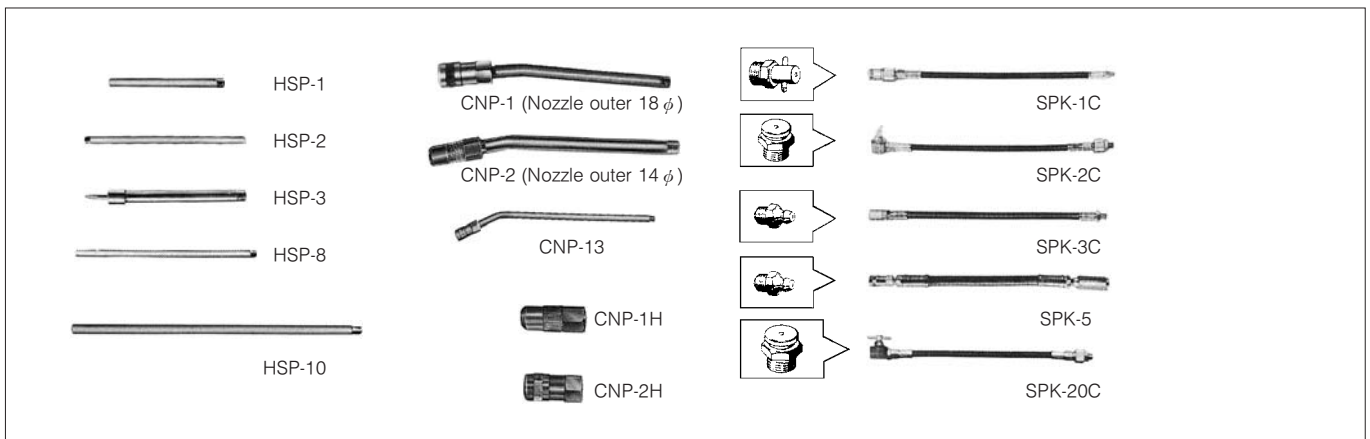

• Straight Nozzle

Model	Length mm	Use
HSP-1	120	Standard Type Nozzle Long Nozzle For Bearing Grease Long Nozzle Long Nozzle
HSP-2	240	
HSP-3	135	
HSP-8	220	
HSP-10	450	

• Hydraulic Chuck Nozzle

Model	Length mm	Use
CNP-1	180	Hydraulic Nipple Hydraulic Nipple Hydraulic Nipple Chuck Nozzle Chuck Nozzle
CNP-2	175	
CNP-13	325	
CNP-1H	-	
CNP-2H	-	

• Micro-Hose

Model	Length mm	Use
SPK-1C	360	Pin Type Fitting Button Head Fitting Hydraulic Nipple Hydraulic Nipple Button Head Fitting
SPK-2C	370	
SPK-3C	340	
SPK-5	410	
SPK-20C	377	

• High Pressure Grease Gun

Model	Remarks
No.632	W/Swivel Joint
Model	Description
800-682	Swivel Joint

LUBRICATING EQUIPMENT

GREASE GUN

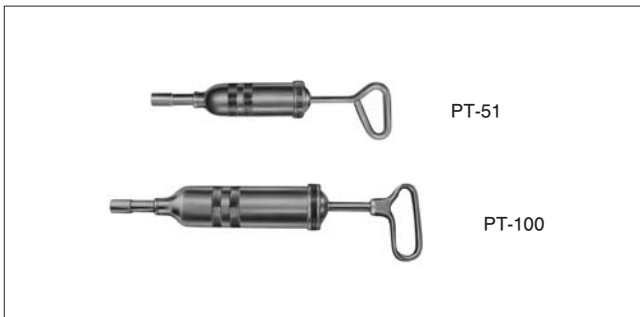

Model	Capacity cc	Overall Length mm	Max. Pressure MPa(kgf/cm ²)	Weight kg
PT-51	50	279	9.8 (100)	320
PT-100	100	306	9.8 (100)	360

OIL SYRINGE

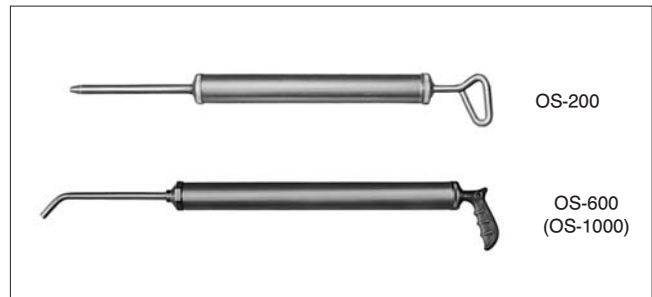

Model	Capacity cc	Tank Dia. x Length mm	Weight kg
OS-200	160	φ 32 × 490	0.57
OS-600	540	φ 50 × 671	1.28
OS-1000	870	φ 50 × 866	1.77

LUBRICATION DRUM SET



This is a pump set in which an oil pump, oil gun and lubrication hose are provided on a chassis. You can operate this drum set by placing a 200 liter drum on it.

Model	LDS-110	LDS-110K	LDS-110R
Pump (DR-110A5)	○	—	○
Pump (KP-110)	—	○	—
Air Regulator	○	○	○
Grip Meter	○	○	○
Nozzle	○	○	○
Swivel Joint E	○	○	○
H.P. Hose	5m	5m	5m
Hose Reel	—	—	○
Cart	○	○	○

DRUM PUMP (OIL LEVEL ALARM)

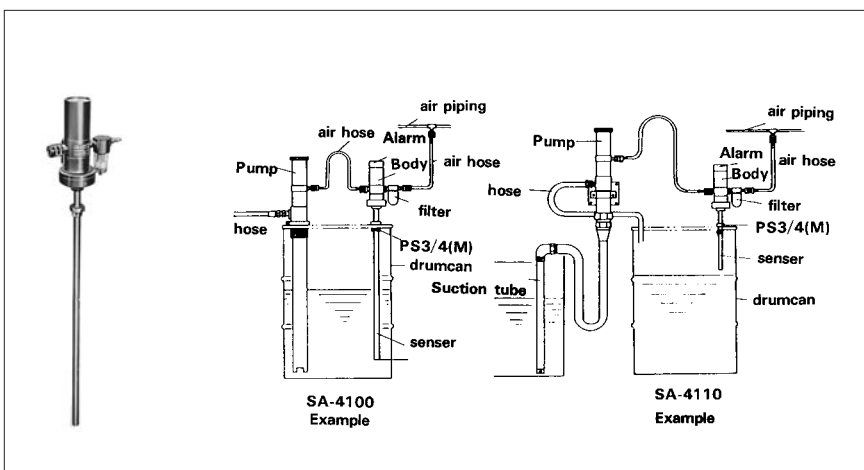

Model	SA-4100	SA-4110
Use	Detect of lower	Detect of upper
Output flow Q'ty N ℓ /min.	1,000	
Air Pressure MPa (kgf/cm ²)	0.2 – 0.69 (2 – 7)	
Output Terminal	¼PT(F)	
Mounting Adaptor	PS ¾(M) Drum can spec.	

CAN CRUSHER



These equipments crush empty cans by means of air pressure.

You can use junk storage space effectively.

Model	CCR-80
Air Pressure MPa(kgf/cm ²)	0.78 – 0.98 (8 – 10)
Dimensions (W×D×H) mm	700×400×750
Weight kg	86
Available Kinds of Cans	4 ℓ Can (Sq.), 1 – 2 ℓ Can (R), Coolant Can, Brakefluid Can, Calibration Gas Can, Aerosol Can, Juice Can

• Crusher for Oil Can only

Model	C²-1000
Air Pressure MPa(kgf/cm ²)	0.58 (6) or more
Dimensions (W×D×H) mm	455×544×805
Weight kg	85
Available Kinds of Cans	1 – 4 ℓ Can

• Clasher for Oil Element can

Model	C²-4000
Air Pressure MPa(kgf/cm ²)	0.58 (6) or more
Dimensions (W×D×H) mm	535×751×805
Weight kg	170
Available Kinds of Cans	Large Vehicle – Passenger Cars, Oil Element, 1 – 4 ℓ Oil Can

OIL MEASURE



• Oil Measure

Model	Capacity ℓ	Remarks
F-210	1	Polyethylene Made
F-220	2	
F-230	3	
F-240	4	
F-250	5	
F-310	1	Polyethylene Made with Cap
F-320	2	

LUBRICATING EQUIPMENT

OILER



Model	Capacity cc	Material
F-302	180	Polyethylene Made
F-204	400	Polyethylene Made
F-301	180	Polyethylene Made
PO-10	250	Aluminum-Alloy
PO-11	330	Aluminum-Alloy

POLYETHYLEN CAN



Model	Capacity ℓ	Remarks
PJ-10	10	Red, without Nozzle
PJ-20	20	
PJ-10NS	Nozzle set for PJ-10	
PJ-20NS	Nozzle set for PJ-20	

GASOLINE HANDY CAN

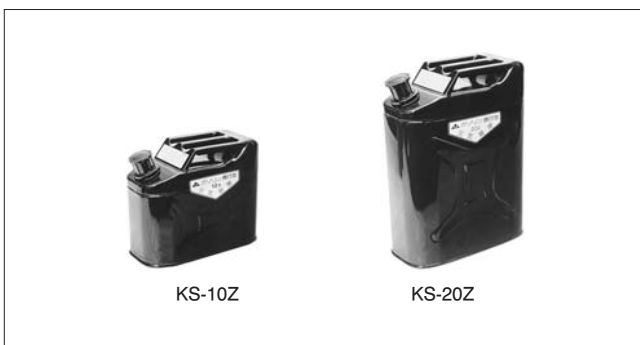

Model	Capacity ℓ	Remarks
KS-10Z	10	– Jeep Mounting Type
KS-20Z	20	

HOSE PUMP

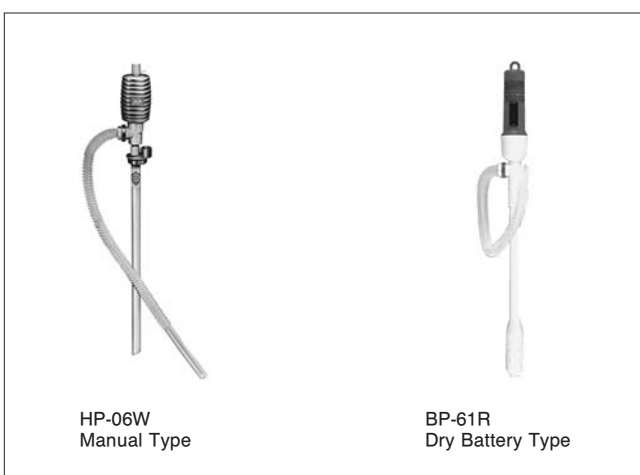

This is a plastic hose pump for 18-liter can use.

HP-06W

Being equipped with a stopping device, this pump prevents any spilling over.

BP-61R

This pump is very handy for transferring oil to a high place (lift 90cm). Simply flicking the switch starts the pump operation.

Model	Output Volume ℓ /min.	Overall Length mm	Remark
HP-06W	6.4	527	–
BP-61R	5.5	625	by dry battery (SUM-1 × 2)

DRUM PUMP (HAND OPERATED)



Model	Output Volume	Overall Length mm	Weight kg	Remarks
HP-26Z	26 ℓ /min.	1,185	0.4	Siphon Type, Plastic
WP-25R WP-50Z	25 ℓ /min. 0.5 ℓ /stroke	1,050 1,310	3 6	Piston Type Piston Type
RP-20Z RP-24Z RP-99Z	0.29 ℓ /revolution 0.34 ℓ /revolution 1 ℓ /revolution	1,245 1,298 1,320	4.3 6.3 7.3	Revolutionary Type Revolutionary Type Revolutionary Type

DRUM PUMP (AC OPERATED)

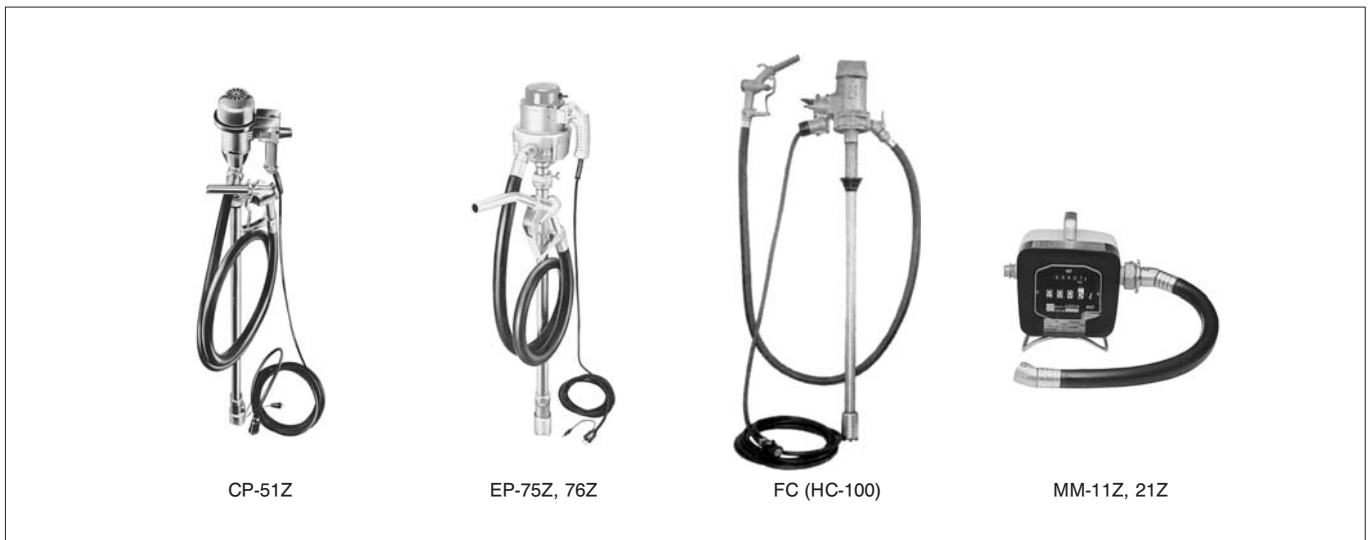

Model	Motor (1-ph.) W	Output Volume ℓ /min.	Remarks
CP-51Z	100	50	—
CP-90Z	110	80	without Nozzle
EP-75Z	65	72	for 50Hz
EP-76Z	65	72	for 60Hz
FC	65	50	Explosion Proof Type
FC-M	65	50	-do-, with Flow Meter
HC-100	65	50	-do- (for Organic Solvent)

• Flow Meter

These flow meters can be used for both of AC or DC and Air Operated Pump in common.

Model	Application
MM-11Z	CP-51Z, CP-31D, CPA-51A
MM-21Z	EP-75Z, EP-76Z, EP-60D

LUBRICATING EQUIPMENT

DRUM PUMP (BATTERY OPERATED)

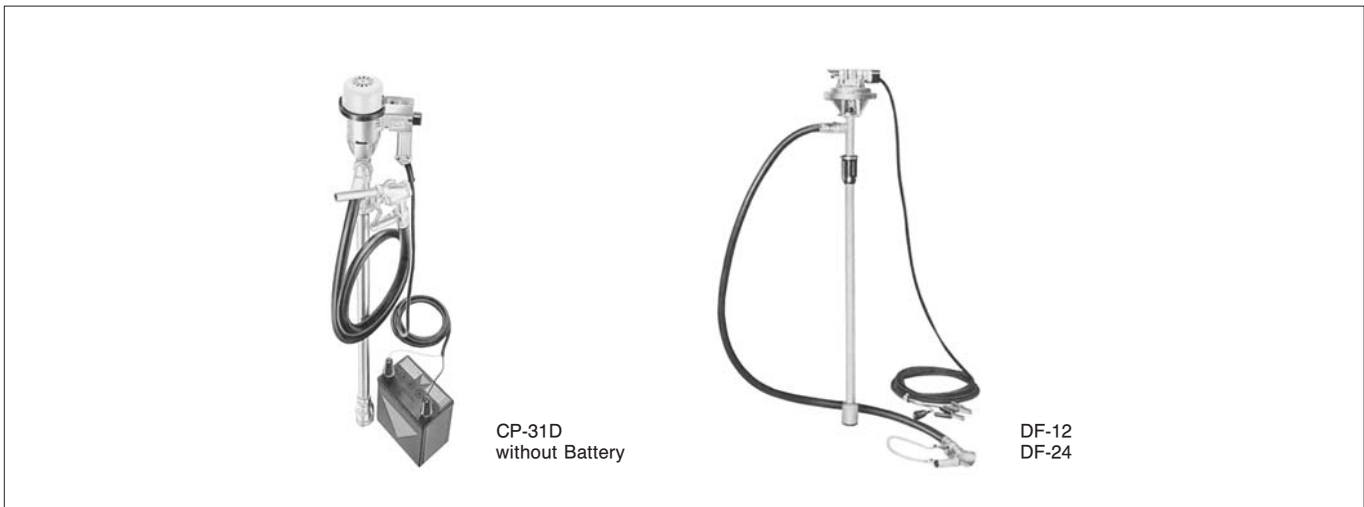

Model	Output Volume ℓ /min.	Current A	Weight kg	Remarks
CP-31D	40	10.5	6	—
EP-60D	60	11.8	9	High Power Type
DF-12 (24)	50	10	8	Explosion Proof Type
DF-M-12 (24)	50	10	8	Explosion Proof Type, with Flow Meter

DRUM PUMP (AIR OPERATED)

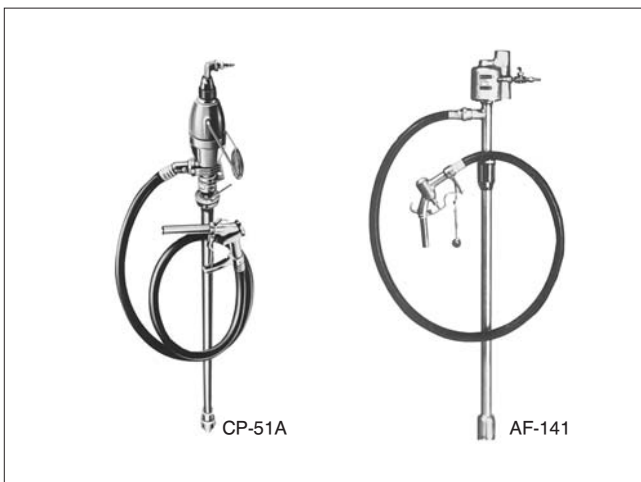

Model	Output Volume ℓ /min.	Weight kg	Remarks
CP-51A	42	5.5	—
AF-141	75	6.5	for Petrochemical
AH-151	90	7.5	for Chemical

DRUM PUMP (AC OPERATED)



This pump featuring high delivery pressure adapts trochoid gears. This is pump exclusively for oils having heavy viscosity.

Model		EP-56A	EP-56B
Motor 1-ph.	W	500	750
Output Volume	ℓ /min.	38	44
Suction Capacity	m	6	6
Pumping Capacity	m	20	30
Weight	kg	30	40

OIL CHANGER



OC-80A



OC-100A

Model		OC-80A	OC-100A
Motor 1-ph.	W	250	250
Suction-Discharge Indication		Reversible Switch	Reversible Switch Limit Switch
Glass Cylinder Capacity	ℓ	10	13
Tank Capacity	ℓ	80	100
Vacuum	mm/Hg	700 more	700 more
Suction Volume	ℓ /min.	1.8-4	3-4
Discharge Volume	ℓ /min.	8	8 more
Suction Pipe O.D.	mm	φ 5, φ 6 (Copper) φ 6 (Teflon)	φ 6 (Steel) φ 6, φ 12 (Teflon)
Oil-proof Hose Length	m	2.2	2.9
Electric Cord Length	m	5	5
Height	mm	1,320	1,370
Width	mm	620	520
Length	mm	510	550
Weight	kg	60	65

PORTABLE OIL CHANGER



This oil changer employs a powerful motor whose output is unusually high for a portable type.

When the oil changer is loaded on a service car, there is no need for concern of waste oil disposal.

Model		P-2
Electric Source		DC12V, 5A 100W
Revolution	rpm	1,100
Tank Capacity	ℓ	10
Suction Pipe Dia.	mm	4
Weight	kg	6.5

AUTOMATIC TRANSMISSION FLUID CHANGER



< Optional Accessories >



AFC-NH
Nozzle Holder



AFC-PCK
Light Vehicle Nozzle



AFC-DA
Direct Adapter



AFC-PCK
Pail Cover Kit



AFC-CKT
Cleaning Kit

Model	AFC-9000S	
Function	1. ATF Changer Mode ① Circulation Mode ② Dipstick Mode ③ CVT Mode ④ Manual Mode (New Oil Supply - Waste Oil Evacuation) ⑤ Function - Cleaning - Waste Oil Drain - New Oil Supply	
	Metering Method: Puls Count	
	Oil Level Control: Oil Sensor ① Waste Oil Tank Full: Alart by Red Lamp & Alarm ② Supply New Oil: Alart by Red Lamp & Alarm	
	Installation: Portable	
Performance	New Oil Supply: 2.2 ℓ /min. (Nozzle φ 6 × φ 4.5) *Oil Temp 20°C	
	Waste Oil Evacuate: 1.4 ℓ /min. (Nozzle φ 6 – φ 4.5) *Oil Temp 50°C	
	Exhaust Evacuation: 3.0 ℓ /min. (Nozzle φ 14 – φ 10) *Oil Temp 20°C	
Power Supply	AC220V 50Hz	
Pump	Trocoird Pump: 2units *Discharge Volume 3.7 ℓ /min. 0.5MPa, with Relief Valve	
	Motor: Type Condenser	
Tank	for Waste oil: 18 ℓ Inner Type for New Oil: Direction New Container	
Hose	Twin Hose for New & Waste 2m (φ 17 – φ 9.5) Hose for Waste 2m (φ 17 – φ 9.5)	
Dimensions (W × H × D)	mm	600 × 1,157 × 564
Weight	kg	49 (without New Pail & Waste Oil in Tank)
Accessory	Nozzle: φ 4 × φ 6 × 1,200mm × 1 Exhaust Extract Nozzle φ 14 × φ 10 × 300mm × 1 Circulation Hose × 2 Type Cleaning Coupler × 1 Nozzle Stand × 3	

OIL CHECKER



In advance, new gear oil or engine oil is put into the piston section having an injector shape. Then, the used oil is sucked into the cylinder section. Being made of hard, transparent plastic, the oil checker allows you to distinguish the color phase readily.

Model	Remarks
iTC-50A	One set of two pieces

DRUM CARRIER



Model	Description	Remarks
DC-250	Drum Can Carrier	250kg capacity
W4-90220	Drakoro	Drum can is rolled by this.

DRUM STAND



Model	Overall Length mm	Weight kg
DS-100	680	8

without Drum Can Cock

DRUM SPANNER



Model	Overall Length mm	Weight kg
KSK-500B	590	2

LUBRICATING EQUIPMENT

DRAIN PLUG WRENCH

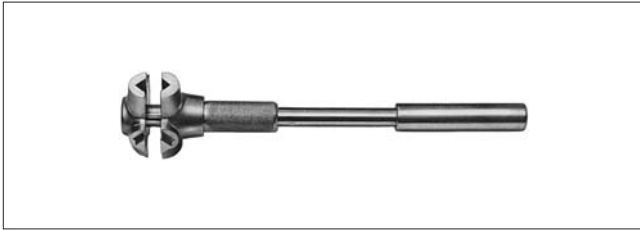

Model	Overall Length mm	Remarks
DW-280	280	Universal Type

DRAIN PLUG WRENCH SET



Model	Set Contents	Metal Case mm
4202	8S × 10S, 8H × 3/8H, 10H × 11H 12H × 13H, 14H × 17H 19H, 4102	145 × 45 × 28

DRUM TAP



Model	Use	Weight kg
GC-57A	for Hole 50mm (2")	2.0

DRUM CAN DIP-STICK

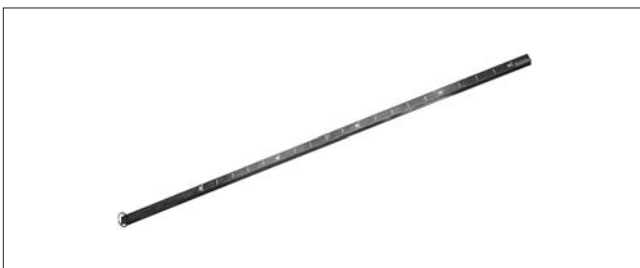

Model	Graduation ℓ	Overall Length mm
DD-1C	0 - 200 (10)	1,010

OIL PRESSURE SWITCH SOCKET



Model	Size mm
4S-24LO	24
4S-26LO	26
4S-27LO	27

OIL FILTER WRENCH

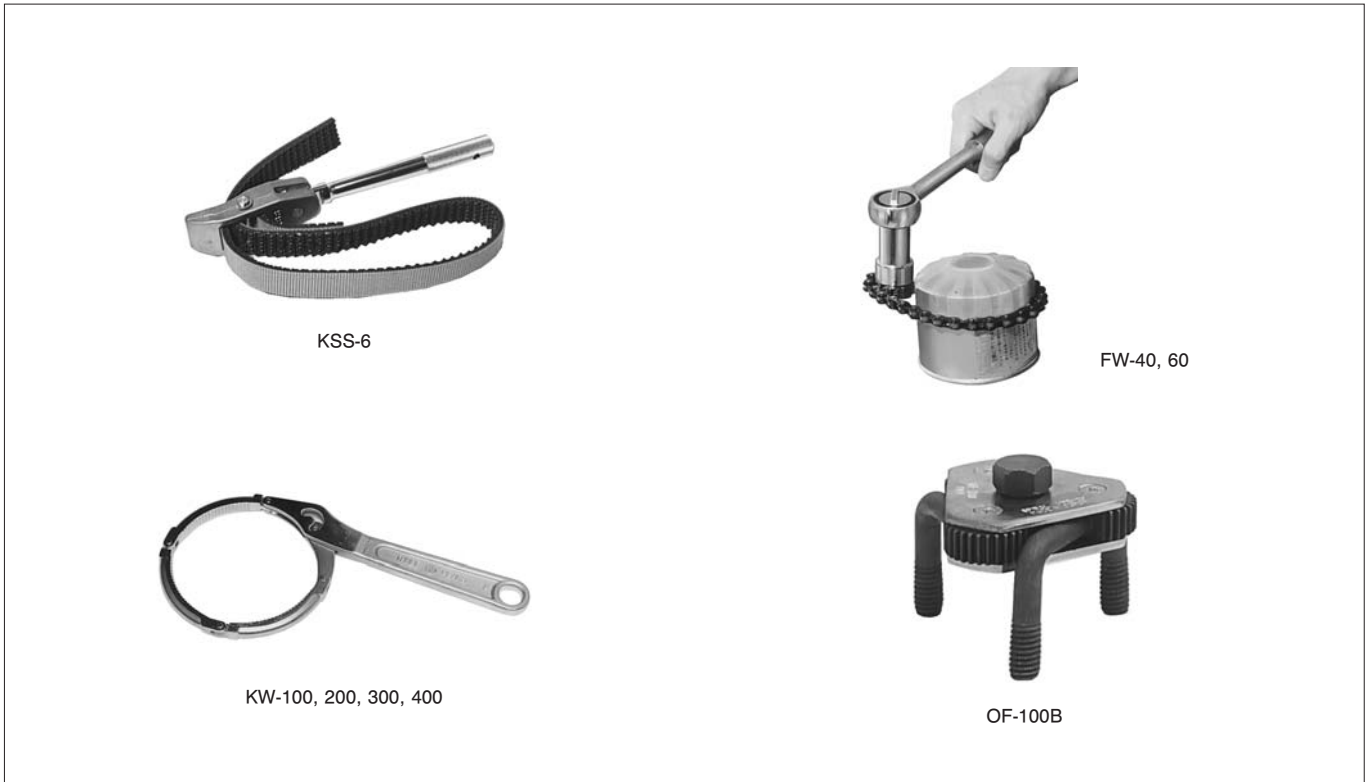

Model	Remarks
KSS-6	Belt Tightening Type
FW-40 FW-60	Chain Type 80 – 115mm Chain Type Max. 160mm

Model	Remarks
KW-100 KW-200 KW-300 KW-400	3point Tightening Type 55 – ϕ 75mm 3point Tightening Type 75 – ϕ 95mm 3point Tightening Type 95 – ϕ 115mm 3point Tightening Type 110 – ϕ 145mm
OF-100B	Opening Range 51 – ϕ 130mm

OIL FILTER WRENCH SET



Model	NT-1	K-1	S-1	N-4	NT-2	NT-3	S-3	N-2	T-2	T-4	M-2	NT-328
	64mm	66.5mm	72.5mm	74mm	79mm	79.5mm	89mm	92mm	94.5mm	99mm	100.5mm	ϕ 75-95mm
NT-600	○	○	○		○	○						○
NT-800	○	○	○		○	○		○	○	○		
NT-1100	○	○	○	○	○	○	○	○	○	○	○	

GREASE CHARGER



Model	Applicable Bearing Size	Applicable Grease Can Size	Weight kg
GZ-18	50 – ϕ 100	20 ℓ Round-Can	8.2